

Prüfbericht-Nr.: <i>Test Report No.:</i>	50172127-001	Auftrags-Nr.: <i>Order No.:</i>	154334770	Seite 1 von 11 <i>Page 1 of 11</i>	
Kunden-Referenz-Nr.: <i>Client Reference No.:</i>	N/A	Auftragsdatum: <i>Order date:</i>	09.08.2018		
Auftraggeber: <i>Client:</i>	Guangzhou Jing Sheng Machine Co.,LTD/N0100 East Wreath Road Luojia Village Shiji Town Panyu Guangzhou China Gu 511450.				
Prüfgegenstand: <i>Test item:</i>	6" center locking caster				
Bezeichnung / Typ-Nr.: <i>Identification / Type No.:</i>	Article No.:KKC607CL				
Auftrags-Inhalt: <i>Order content:</i>	Mechanical test report according to client's requirements				
Prüfgrundlage: <i>Test specification:</i>	AS 1961.6—2004(w/o cl.7) Castors and wheels Part 6: Hospital bed castors				
Wareneingangsdatum: <i>Date of receipt:</i>	09.08.2018				
Prüfmuster-Nr.: <i>Test sample No.:</i>	A000788800-001, 002				
Prüfzeitraum: <i>Testing period:</i>	09.08.2018 - 17.08.2018				
Ort der Prüfung: <i>Place of testing:</i>	Shanghai				
Prüflaboratorium: <i>Testing laboratory:</i>	TÜV Rheinland (Shanghai) Co., Ltd.				
Prüfergebnis*: <i>Test result*:</i>	Pass				
geprüft von / tested by:	<i>Ricky</i>				kontrolliert von / reviewed by:
17.08.2018 Ricky Wang/ PE		17.08.2018 Tu Feng / Reviewer			
Datum <i>Date</i>	Name / Stellung <i>Name / Position</i>	Unterschrift <i>Signature</i>	Datum <i>Date</i>	Name / Stellung <i>Name / Position</i>	Unterschrift <i>Signature</i>
Sonstiges / Other: Acc. to client's request, the evaluation of AS 1961.6-2004 cl. 7 Marking was not performed.					
Zustand des Prüfgegenstandes bei Anlieferung: <i>Condition of the test item at delivery:</i>			Prüfmuster vollständig und unbeschädigt <i>Test item complete and undamaged</i>		
<p>* Legende: 1 = sehr gut 2 = gut 3 = befriedigend 4 = ausreichend 5 = mangelhaft P(ass) = entspricht o.g. Prüfgrundlage(n) F(ail) = entspricht nicht o.g. Prüfgrundlage(n) N/A = nicht anwendbar N/T = nicht getestet</p> <p>Legend: 1 = very good 2 = good 3 = satisfactory 4 = sufficient 5 = poor P(ass) = passed a.m. test specification(s) F(ail) = failed a.m. test specification(s) N/A = not applicable N/T = not tested</p>					
<p>Dieser Prüfbericht bezieht sich nur auf das o.g. Prüfmuster und darf ohne Genehmigung der Prüfstelle nicht auszugsweise vervielfältigt werden. Dieser Bericht berechtigt nicht zur Verwendung eines Prüfzeichens. <i>This test report only relates to the a. m. test sample. Without permission of the test center this test report is not permitted to be duplicated in extracts. This test report does not entitle to carry any test mark.</i></p>					

Prüfbericht-Nr.: 50172127-001
Test Report No.:

Seite 3 von 11
Page 3 of 11

Produktbeschreibung
Product description

1	Produktdetails <i>Product details</i>	6" center locking caster
2	Maße / Gewicht <i>Dimensions / Weight</i>	Weight: 1.29kg
3	Bedienelemente <i>Operating elements</i>	N/A
4	Ausstattung / Zubehör <i>Equipment / Accessories</i>	N/A
5	Verwendete Materialien <i>Used materials</i>	N/A
6	Sonstiges <i>Other</i>	Load capacity: 150kg (1500N).

Castor

Castor removed the plastic housing



Locking device worked

Stem

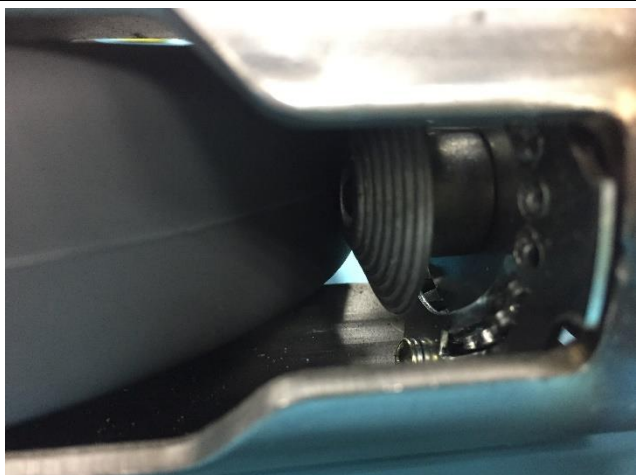

Prüfbericht-Nr.: 50172127-001 <i>Test Report No.:</i>		Seite 4 von 11 Page 4 of 11	
Absatz	AS 1961.6—2004(w/o cl.7)	Messergebnisse - Bemerkungen	Bewertung
Clause	Anforderungen - Prüfungen / Requirements - Tests	Measuring results - Remarks	Evaluation
1	Scope This International Standard specifies the technical requirements, the appropriate dimensions and the requirements for testing of swivel castors for hospital beds with a wheel diameter of 100mm or more, and which have a central locking device. Swivel castors may be used with the main principal dimensions.		
2	Normative references The following referenced documents are indispensable for the application of this document. For dated references, only the edition cited applies. For undated references, the latest edition of the referenced document (including any amendments) applies. ISO 22877, <i>Castors and wheels — Vocabulary, symbols and multilingual terminology</i> ISO 22878:2004, <i>Castors and wheels — Test methods and apparatus</i> ISO 22881, <i>Castors and wheels — Requirements for use on manually propelled equipment for institutional applications</i>		
3	Terms and definitions For the purposes of this document, the terms and definitions given in ISO 22877 apply. Symbols are given in ISO 22878:2004, Annex A.		
4	Dimensions and characteristics		
4.1	Characteristics The characteristics of a castor are — wheel diameter, — overall height, — offset, — fixing system, and — load capacity. Dimensions The dimensions listed in Table 1 and shown in Figure 1 shall be used. For dimensions of non-central locking castors used in hospital beds, refer to relevant tables in ISO 22881.	D: 150.46mm H: 192.60mm F: 43.03mm 150kg	P

Prüfbericht-Nr.: 50172127-001
Test Report No.:

Seite 5 von 11
Page 5 of 11

Absatz	AS 1961.6—2004(w/o cl.7)	Messergebnisse - Bemerkungen	Bewertung
Clause	Anforderungen - Prüfungen / Requirements - Tests	Measuring results - Remarks	Evaluation

Dimensions in millimetres

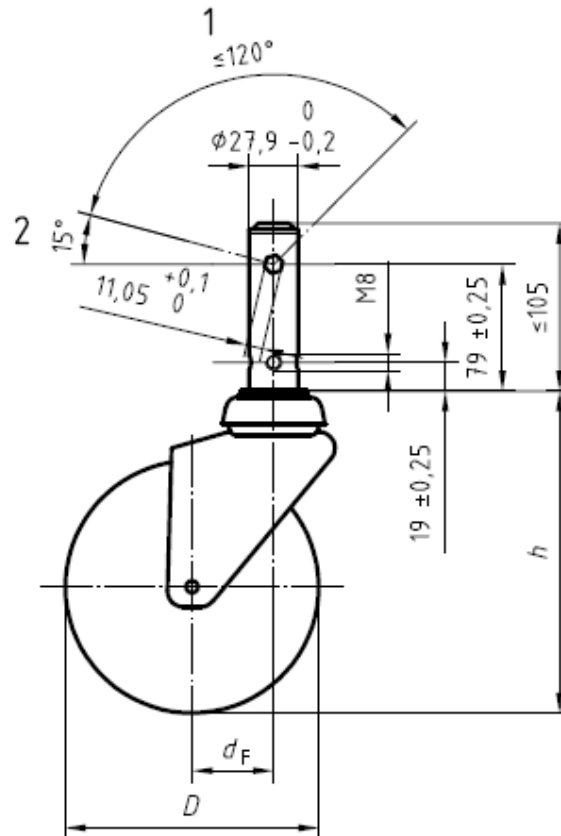

Key
1 working angle
2 unlocked position

Figure 1 — Principal dimensions of the central locking fixing system

Table 1

Dimensions in millimetres

Wheel diameter ^a <i>D</i>	Overall height ^b <i>h</i>	Offset ^b <i>d_F</i>
100	150	46
125	175	56
150	200	65
200	250	70
250	300	80

^a Tolerance $\pm 1\%$.

^b Maximum.

Prüfbericht-Nr.: 50172127-001 Test Report No.:																	
Absatz	AS 1961.6—2004(w/o cl.7)	Messergebnisse - Bemerkungen	Bewertung														
Clause	Anforderungen - Prüfungen / Requirements - Tests	Measuring results - Remarks	Evaluation														
4.3	<p>Fixing system</p> <p>The principal dimensions of the fixing system with the central locking are</p> <ul style="list-style-type: none"> — stem length, — stem diameter, — distance of the threaded hole centre from the stem collar, — thread size, — distance of the hexagon hole centre from the stem collar, — dimension of the hexagon hole, and — working angle of the hexagon hole. 	<p>98.31mm</p> <p>27.89mm</p> <p>19.17mm</p> <p>M8</p> <p>79.14mm</p> <p>11.10mm</p> <p>82.35°</p>	P														
4.4	<p>Load capacity</p> <p>This is the maximum load, in newtons, which can be carried by a wheel or a castor so as to fully comply with the required acceptance criteria.</p>																
5	Requirements for testing																
5.1	<p>General</p> <p>Test methods and apparatus shall be as specified in ISO 22878.</p>																
5.2	Standard conditions																
5.3	<p>Initial wheel play</p> <p>5.3.1 Test objectives, apparatus and procedures These shall be as specified in ISO 22878:2004, 4.2. Acceptance criteria</p> <p>5.3.2 The measured initial wheel play shall not exceed the value (d_{w1}) given in Table 3.</p> <p style="text-align: center;">Table 3</p> <p style="text-align: center;">Dimensions in millimetres</p> <table border="1" style="margin-left: auto; margin-right: auto;"> <thead> <tr> <th>Wheel diameter</th> <th>Maximum initial wheel play</th> </tr> <tr> <th>D</th> <th>d_{w1}</th> </tr> </thead> <tbody> <tr> <td>100</td> <td>0,50</td> </tr> <tr> <td>125</td> <td>0,62</td> </tr> <tr> <td>150</td> <td>0,75</td> </tr> <tr> <td>200</td> <td>1,00</td> </tr> <tr> <td>250</td> <td>1,25</td> </tr> </tbody> </table>	Wheel diameter	Maximum initial wheel play	D	d_{w1}	100	0,50	125	0,62	150	0,75	200	1,00	250	1,25	<p><i>Requirement :</i></p> <p>Wheel dia.: 150mm</p> <p>W1: Max 0.75mm</p> <p><i>Result:</i></p> <p>W1: 0.17mm</p>	P
Wheel diameter	Maximum initial wheel play																
D	d_{w1}																
100	0,50																
125	0,62																
150	0,75																
200	1,00																
250	1,25																
5.4	<p>Initial swivel play</p> <p>5.4.1 Test objectives, apparatus and procedures These shall be as specified in ISO 22878:2004, 4.3.</p> <p>5.4.2 Acceptance criteria The measured initial swivel play shall not exceed the value (d_{s1}) given in Table 4.</p> <p style="text-align: center;">Table 4</p> <table border="1" style="margin-left: auto; margin-right: auto;"> <thead> <tr> <th>Symbol</th> <th>Value</th> <th>Description</th> </tr> </thead> <tbody> <tr> <td>d_{s1}</td> <td>4 mm</td> <td>maximum initial swivel play</td> </tr> </tbody> </table>	Symbol	Value	Description	d_{s1}	4 mm	maximum initial swivel play	<p><i>Requirement :</i></p> <p>Wheel dia.: 150mm</p> <p>S1: max 4mm</p> <p><i>Result:</i></p> <p>S1: 0.69mm</p>	P								
Symbol	Value	Description															
d_{s1}	4 mm	maximum initial swivel play															

Absatz	AS 1961.6—2004(w/o cl.7)	Messergebnisse - Bemerkungen	Bewertung
Clause	Anforderungen - Prüfungen / Requirements - Tests	Measuring results - Remarks	Evaluation

5.5	<p>Electrical resistance test</p> <p>5.5.1 Test objectives, apparatus and procedures These shall be as specified in ISO 22878:2004, 4.4.</p> <p>5.5.2 Test values The test values shall be as listed in Table 5.</p> <p style="text-align: center;">Table 5</p> <table border="1" style="width: 100%;"> <thead> <tr> <th>Symbol</th> <th>Value</th> <th>Description</th> </tr> </thead> <tbody> <tr> <td>F_{max}</td> <td>variable</td> <td>load capacity</td> </tr> <tr> <td>F_{17}</td> <td>10 % of F_{max}</td> <td>test load</td> </tr> <tr> <td>R</td> <td>variable</td> <td>electrical resistance</td> </tr> </tbody> </table> <p>5.5.3 Tolerances The tolerance shall be as shown in Table 6.</p> <p style="text-align: center;">Table 6</p> <table border="1" style="width: 100%;"> <thead> <tr> <th rowspan="2">Symbol</th> <th rowspan="2">Unit</th> <th colspan="2">Tolerance</th> </tr> <tr> <th>Acceptable</th> <th>Unit</th> </tr> </thead> <tbody> <tr> <td>F_{17}</td> <td>N</td> <td>$\begin{matrix} +2\% \\ 0 \end{matrix}$</td> <td>N</td> </tr> </tbody> </table> <p>5.5.4 Acceptance criteria The resistance R of the sample tested shall be — $R \leq 10^5 \Omega$ for conductive castors or wheels, and — $10^5 \Omega < R \leq 10^7 \Omega$ for antistatic castors or wheels.</p>	Symbol	Value	Description	F_{max}	variable	load capacity	F_{17}	10 % of F_{max}	test load	R	variable	electrical resistance	Symbol	Unit	Tolerance		Acceptable	Unit	F_{17}	N	$\begin{matrix} +2\% \\ 0 \end{matrix}$	N	<p><i>Conductive castor(s) or wheel(s): $R \leq 10^5 \Omega$</i></p> <p><i>Result: 1136Ω</i></p> <p><i>Test load: 10% claim load=150. 0N</i></p>	P
Symbol	Value	Description																							
F_{max}	variable	load capacity																							
F_{17}	10 % of F_{max}	test load																							
R	variable	electrical resistance																							
Symbol	Unit	Tolerance																							
		Acceptable	Unit																						
F_{17}	N	$\begin{matrix} +2\% \\ 0 \end{matrix}$	N																						

5.6	<p>Fatigue test for locking/braking device</p> <p>5.6.1 Test objectives, apparatus and procedures These shall be as specified in ISO 22878:2004, 4.5.</p> <p>5.6.2 Test values The test values shall be as listed in Table 7.</p> <p style="text-align: center;">Table 7</p> <table border="1" style="width: 100%;"> <thead> <tr> <th>Symbol</th> <th>Value</th> <th>Description</th> </tr> </thead> <tbody> <tr> <td>n_E</td> <td>10 000</td> <td>number of locking actions</td> </tr> <tr> <td>f_E</td> <td>10 cycles/min</td> <td>frequency of locking actions</td> </tr> <tr> <td>F_3</td> <td>800 N</td> <td>test load</td> </tr> </tbody> </table> <p>5.6.3 Tolerances The tolerances shall be as shown in Table 8.</p> <p style="text-align: center;">Table 8</p> <table border="1" style="width: 100%;"> <thead> <tr> <th rowspan="2">Symbol</th> <th rowspan="2">Unit</th> <th colspan="2">Tolerance</th> </tr> <tr> <th>Acceptable</th> <th>Unit</th> </tr> </thead> <tbody> <tr> <td>n_E</td> <td>—</td> <td>$\begin{matrix} +1\% \\ 0 \end{matrix}$</td> <td>—</td> </tr> <tr> <td>f_E</td> <td>cycles/min</td> <td>$\begin{matrix} 0 \\ -2 \end{matrix}$</td> <td>cycles/min</td> </tr> <tr> <td>F_3</td> <td>N</td> <td>$\begin{matrix} +2\% \\ 0 \end{matrix}$</td> <td>N</td> </tr> </tbody> </table> <p>5.6.4 Acceptance criteria There shall be no wear and/or permanent deformation that adversely affects the performance of the sample.</p>	Symbol	Value	Description	n_E	10 000	number of locking actions	f_E	10 cycles/min	frequency of locking actions	F_3	800 N	test load	Symbol	Unit	Tolerance		Acceptable	Unit	n_E	—	$\begin{matrix} +1\% \\ 0 \end{matrix}$	—	f_E	cycles/min	$\begin{matrix} 0 \\ -2 \end{matrix}$	cycles/min	F_3	N	$\begin{matrix} +2\% \\ 0 \end{matrix}$	N	<p><i>No failure was found with braking/locking</i></p>	P
Symbol	Value	Description																															
n_E	10 000	number of locking actions																															
f_E	10 cycles/min	frequency of locking actions																															
F_3	800 N	test load																															
Symbol	Unit	Tolerance																															
		Acceptable	Unit																														
n_E	—	$\begin{matrix} +1\% \\ 0 \end{matrix}$	—																														
f_E	cycles/min	$\begin{matrix} 0 \\ -2 \end{matrix}$	cycles/min																														
F_3	N	$\begin{matrix} +2\% \\ 0 \end{matrix}$	N																														

Prüfbericht-Nr.: 50172127-001
Test Report No.:

Seite 8 von 11
Page 8 of 11

Absatz	AS 1961.6—2004(w/o cl.7)	Messergebnisse - Bemerkungen	Bewertung
Clause	Anforderungen - Prüfungen / Requirements - Tests	Measuring results - Remarks	Evaluation

<p>5.7</p> <p>Efficiency check of wheel braking and/or locking devices</p> <p>5.7.1 Test objectives, apparatus and procedures These shall be as specified in ISO 22878:2004, 4.6.</p> <p>5.7.2 Test values The test values shall be as listed in Table 9.</p> <p style="text-align: center;">Table 9</p> <table border="1"> <thead> <tr> <th>Symbol</th> <th>Value</th> <th>Description</th> </tr> </thead> <tbody> <tr> <td>F_{max}</td> <td>variable</td> <td>load capacity</td> </tr> <tr> <td>F_{11}</td> <td>equal to F_{max}</td> <td>test load</td> </tr> <tr> <td>F_{K1}</td> <td>40 % of F_{max}</td> <td>horizontal tractive force</td> </tr> </tbody> </table> <p>5.7.3 Tolerances The tolerances shall be as shown in Table 10.</p> <p style="text-align: center;">Table 10</p> <table border="1"> <thead> <tr> <th rowspan="2">Symbol</th> <th rowspan="2">Unit</th> <th colspan="2">Tolerance</th> </tr> <tr> <th>Acceptable</th> <th>Unit</th> </tr> </thead> <tbody> <tr> <td>F_{11}</td> <td>N</td> <td>+2 % 0</td> <td>N</td> </tr> <tr> <td>F_{K1}</td> <td>N</td> <td>+4 % 0</td> <td>N</td> </tr> </tbody> </table> <p>5.7.4 Acceptance criteria The wheel shall have no revolving movement around its axis during the second application of the force F_{K1}.</p>	Symbol	Value	Description	F_{max}	variable	load capacity	F_{11}	equal to F_{max}	test load	F_{K1}	40 % of F_{max}	horizontal tractive force	Symbol	Unit	Tolerance		Acceptable	Unit	F_{11}	N	+2 % 0	N	F_{K1}	N	+4 % 0	N	<p>P</p> <p><i>No revolving movement of the wheel around its axis</i></p> <p><i>Test load: 40% claim load=600N</i></p>
Symbol	Value	Description																									
F_{max}	variable	load capacity																									
F_{11}	equal to F_{max}	test load																									
F_{K1}	40 % of F_{max}	horizontal tractive force																									
Symbol	Unit	Tolerance																									
		Acceptable	Unit																								
F_{11}	N	+2 % 0	N																								
F_{K1}	N	+4 % 0	N																								

<p>5.8</p> <p>Efficiency check of swivel braking and/or locking devices</p> <p>5.8.1 Test objectives, apparatus and procedures These shall be as specified in ISO 22878:2004, 4.7.</p> <p>5.8.2 Test values The test values shall be as listed in Table 11.</p> <p style="text-align: center;">Table 11</p> <table border="1"> <thead> <tr> <th>Symbol</th> <th>Value</th> <th>Description</th> </tr> </thead> <tbody> <tr> <td>F_{max}</td> <td>variable</td> <td>load capacity</td> </tr> <tr> <td>F_{11}</td> <td>equal to F_{max}</td> <td>test load</td> </tr> <tr> <td>F_{K2}</td> <td>40 % of F_{max}</td> <td>horizontal tractive force</td> </tr> </tbody> </table> <p>5.8.3 Tolerances The tolerances shall be as shown in Table 12.</p> <p style="text-align: center;">Table 12</p> <table border="1"> <thead> <tr> <th rowspan="2">Symbol</th> <th rowspan="2">Unit</th> <th colspan="2">Tolerance</th> </tr> <tr> <th>Acceptable</th> <th>Unit</th> </tr> </thead> <tbody> <tr> <td>F_{11}</td> <td>N</td> <td>+2 % 0</td> <td>N</td> </tr> <tr> <td>F_{K2}</td> <td>N</td> <td>+4 % 0</td> <td>N</td> </tr> </tbody> </table> <p>5.8.4 Acceptance criteria No swivelling movement shall be detected during the second application of the force F_{K2}.</p>	Symbol	Value	Description	F_{max}	variable	load capacity	F_{11}	equal to F_{max}	test load	F_{K2}	40 % of F_{max}	horizontal tractive force	Symbol	Unit	Tolerance		Acceptable	Unit	F_{11}	N	+2 % 0	N	F_{K2}	N	+4 % 0	N	<p>P</p> <p><i>No swiveling movement is detected</i></p> <p><i>Test load: 40% claim load=600N</i></p>
Symbol	Value	Description																									
F_{max}	variable	load capacity																									
F_{11}	equal to F_{max}	test load																									
F_{K2}	40 % of F_{max}	horizontal tractive force																									
Symbol	Unit	Tolerance																									
		Acceptable	Unit																								
F_{11}	N	+2 % 0	N																								
F_{K2}	N	+4 % 0	N																								

Prüfbericht-Nr.: 50172127-001
Test Report No.:

Seite 9 von 11
Page 9 of 11

Absatz	AS 1961.6—2004(w/o cl.7)	Messergebnisse - Bemerkungen	Bewertung
Clause	Anforderungen - Prüfungen / Requirements - Tests	Measuring results - Remarks	Evaluation

<p>5.9</p>	<p>Static test</p> <p>5.9.1 Test objectives, apparatus and procedures These shall be as specified in ISO 22878:2004, 4.9.</p> <p>5.9.2 Test values The test values shall be as listed in Table 13.</p> <p style="text-align: center;">Table 13</p> <table border="1"> <thead> <tr> <th>Symbol</th> <th>Value</th> <th>Description</th> </tr> </thead> <tbody> <tr> <td>F_{max}</td> <td>variable</td> <td>load capacity</td> </tr> <tr> <td>y_1</td> <td>3</td> <td>load factor</td> </tr> <tr> <td>F_0</td> <td>$F_{max} \times y_1$</td> <td>test load</td> </tr> <tr> <td>t_{y1}</td> <td>1 h</td> <td>time of application of the load</td> </tr> <tr> <td>t_{y2}</td> <td>24 h</td> <td>time elapsed prior to inspection</td> </tr> </tbody> </table> <p>5.9.3 Tolerances The tolerances shall be as shown in Table 14.</p> <p style="text-align: center;">Table 14</p> <table border="1"> <thead> <tr> <th rowspan="2">Symbol</th> <th rowspan="2">Unit</th> <th colspan="2">Tolerance</th> </tr> <tr> <th>Acceptable</th> <th>Unit</th> </tr> </thead> <tbody> <tr> <td>F_0</td> <td>N</td> <td>+2 % 0</td> <td>N</td> </tr> <tr> <td>t_{y1}</td> <td>h</td> <td>+15 0</td> <td>min</td> </tr> <tr> <td>t_{y2}</td> <td>h</td> <td>± 1</td> <td>h</td> </tr> </tbody> </table> <p>5.9.4 Acceptance criteria There shall be no permanent deformation of the sample that adversely affects its performance.</p>	Symbol	Value	Description	F_{max}	variable	load capacity	y_1	3	load factor	F_0	$F_{max} \times y_1$	test load	t_{y1}	1 h	time of application of the load	t_{y2}	24 h	time elapsed prior to inspection	Symbol	Unit	Tolerance		Acceptable	Unit	F_0	N	+2 % 0	N	t_{y1}	h	+15 0	min	t_{y2}	h	± 1	h	<p><i>No visible permanent deformation was found</i></p> <p><i>Test load: 3 time of claim load=4500N</i></p>	<p>P</p>
Symbol	Value	Description																																					
F_{max}	variable	load capacity																																					
y_1	3	load factor																																					
F_0	$F_{max} \times y_1$	test load																																					
t_{y1}	1 h	time of application of the load																																					
t_{y2}	24 h	time elapsed prior to inspection																																					
Symbol	Unit	Tolerance																																					
		Acceptable	Unit																																				
F_0	N	+2 % 0	N																																				
t_{y1}	h	+15 0	min																																				
t_{y2}	h	± 1	h																																				
<p>5.10</p>	<p>Dynamic test</p> <p>5.10.1 Test objectives, apparatus and procedures These shall be as specified in ISO 22878:2004, 4.8.</p> <p>5.10.2 Test values The test values shall be as listed in Table 15.</p> <p style="text-align: center;">Table 15</p> <table border="1"> <thead> <tr> <th>Symbol</th> <th>Value</th> <th>Description</th> </tr> </thead> <tbody> <tr> <td>F_{max}</td> <td>variable</td> <td>load capacity</td> </tr> <tr> <td>v_1</td> <td>1,1 m/s (4 km/h)</td> <td>average speed of running period</td> </tr> <tr> <td>v_2</td> <td>1,1 m/s (4 km/h)</td> <td>speed at impact with obstacles</td> </tr> <tr> <td>h_1</td> <td>height of obstacles for wheels with — tread hardness ≥ 90 Shore A: 2,5 % of D — tread hardness < 90 Shore A: 5,0 % of D</td> <td>height of obstacles</td> </tr> <tr> <td>d_o</td> <td>1 m to 3 m</td> <td>distance between obstacles</td> </tr> <tr> <td>n</td> <td>1 000</td> <td>number of obstacles</td> </tr> <tr> <td>n_{r1}</td> <td>30 000</td> <td>number of wheel revolutions</td> </tr> <tr> <td>t_{z1}</td> <td>3 min</td> <td>running period</td> </tr> <tr> <td>t_{z2}</td> <td>1 min</td> <td>pause</td> </tr> <tr> <td>D</td> <td>variable</td> <td>wheel diameter</td> </tr> </tbody> </table> <p>The actual wheel diameter shall be measured prior to commencement and on completion of the test to establish wear.</p> <p>5.10.3 Tolerances The tolerances shall be as shown in Table 16.</p>	Symbol	Value	Description	F_{max}	variable	load capacity	v_1	1,1 m/s (4 km/h)	average speed of running period	v_2	1,1 m/s (4 km/h)	speed at impact with obstacles	h_1	height of obstacles for wheels with — tread hardness ≥ 90 Shore A: 2,5 % of D — tread hardness < 90 Shore A: 5,0 % of D	height of obstacles	d_o	1 m to 3 m	distance between obstacles	n	1 000	number of obstacles	n_{r1}	30 000	number of wheel revolutions	t_{z1}	3 min	running period	t_{z2}	1 min	pause	D	variable	wheel diameter	<p><i>No permanent deformation was found after dynamic test</i></p> <p><i>Before dynamic test of wheel diameter: 150.46mm</i></p> <p><i>After dynamic test of wheel diameter: 150.21mm < 2 % of the measured diameter</i></p> <p><i>Test load: 150kg</i></p>	<p>P</p>			
Symbol	Value	Description																																					
F_{max}	variable	load capacity																																					
v_1	1,1 m/s (4 km/h)	average speed of running period																																					
v_2	1,1 m/s (4 km/h)	speed at impact with obstacles																																					
h_1	height of obstacles for wheels with — tread hardness ≥ 90 Shore A: 2,5 % of D — tread hardness < 90 Shore A: 5,0 % of D	height of obstacles																																					
d_o	1 m to 3 m	distance between obstacles																																					
n	1 000	number of obstacles																																					
n_{r1}	30 000	number of wheel revolutions																																					
t_{z1}	3 min	running period																																					
t_{z2}	1 min	pause																																					
D	variable	wheel diameter																																					

Absatz	AS 1961.6—2004(w/o cl.7)	Messergebnisse - Bemerkungen	Bewertung
Clause	Anforderungen - Prüfungen / Requirements - Tests	Measuring results - Remarks	Evaluation

	<p style="text-align: center;">Table 16</p> <table border="1"> <thead> <tr> <th rowspan="2">Symbol</th> <th rowspan="2">Unit</th> <th colspan="2">Tolerance</th> </tr> <tr> <th>Acceptable</th> <th>Unit</th> </tr> </thead> <tbody> <tr> <td>v_1</td> <td>m/s</td> <td>+5 % 0</td> <td>m/s</td> </tr> <tr> <td>v_2</td> <td>m/s</td> <td>+5 % 0</td> <td>m/s</td> </tr> <tr> <td>h_1</td> <td>mm</td> <td>0 -5 %</td> <td>mm</td> </tr> <tr> <td>n</td> <td>—</td> <td>+1 % 0</td> <td>—</td> </tr> <tr> <td>n_{r1}</td> <td>—</td> <td>+1 % 0</td> <td>—</td> </tr> <tr> <td>t_{z1}</td> <td>min</td> <td>± 10</td> <td>s</td> </tr> </tbody> </table> <p>5.10.4 Acceptance criteria</p> <p>There shall be no permanent deformation of the sample which adversely affects its performance. The reduction of the wheel diameter shall not exceed 2% of the measured diameter at the commencement of the test sequence</p>	Symbol	Unit	Tolerance		Acceptable	Unit	v_1	m/s	+5 % 0	m/s	v_2	m/s	+5 % 0	m/s	h_1	mm	0 -5 %	mm	n	—	+1 % 0	—	n_{r1}	—	+1 % 0	—	t_{z1}	min	± 10	s		
Symbol	Unit			Tolerance																													
		Acceptable	Unit																														
v_1	m/s	+5 % 0	m/s																														
v_2	m/s	+5 % 0	m/s																														
h_1	mm	0 -5 %	mm																														
n	—	+1 % 0	—																														
n_{r1}	—	+1 % 0	—																														
t_{z1}	min	± 10	s																														
5.11	<p>Efficiency check of wheel braking and/or locking devices</p> <p>Repeat test 5.7.</p>	<p><i>No revolving movement of the wheel around its axis</i></p> <p><i>Test load: 40% claim load=600N</i></p>	P																														
5.12	<p>Efficiency check of swivel braking and/or locking devices</p> <p>Repeat test 5.8.</p>	<p><i>No swiveling movement is detected</i></p> <p><i>Test load: 40% claim load=600N</i></p>	P																														
5.13	<p>Final wheel play</p> <p>5.13.1 Test objectives, apparatus and procedures These shall be as specified in ISO 22878:2004, 4.2.</p> <p>5.13.2 Acceptance criteria</p> <p>The wheel wear play shall not exceed the value d_{w2} detailed in Table 17.</p> <p style="text-align: center;">Table 17</p> <p style="text-align: center;">Dimensions in millimetres</p> <table border="1"> <thead> <tr> <th>Wheel diameter D</th> <th>Maximum wheel wear play d_{w2}</th> </tr> </thead> <tbody> <tr> <td>100</td> <td>0,50</td> </tr> <tr> <td>125</td> <td>0,62</td> </tr> <tr> <td>150/160</td> <td>0,75</td> </tr> <tr> <td>200</td> <td>1,00</td> </tr> <tr> <td>250</td> <td>1,25</td> </tr> </tbody> </table>	Wheel diameter D	Maximum wheel wear play d_{w2}	100	0,50	125	0,62	150/160	0,75	200	1,00	250	1,25	<p><i>Requirement: Wheel dia.: 150mm W2: Max 0.75mm</i></p> <p><i>Result: W2: 0.23mm</i></p>	P																		
Wheel diameter D	Maximum wheel wear play d_{w2}																																
100	0,50																																
125	0,62																																
150/160	0,75																																
200	1,00																																
250	1,25																																

Prüfbericht-Nr.: 50172127-001 Test Report No.:		Seite 11 von 11 Page 11 of 11							
Absatz	AS 1961.6—2004(w/o cl.7)	Messergebnisse - Bemerkungen	Bewertung						
Clause	Anforderungen - Prüfungen / Requirements - Tests	Measuring results - Remarks	Evaluation						
5.14	<p>Final swivel play</p> <p>5.14.1 Test objectives, apparatus and procedures These shall be as specified in ISO 22878:2004, 4.3.</p> <p>5.14.2 Acceptance criteria The swivel wear play calculated from the difference between the measured initial and final swivel play shall not exceed the value d_{s2} listed in Table 18.</p> <p style="text-align: center;">Table 18</p> <table border="1" style="margin-left: auto; margin-right: auto;"> <thead> <tr> <th>Symbol</th> <th>Value</th> <th>Description</th> </tr> </thead> <tbody> <tr> <td>d_{s2}</td> <td>4 mm</td> <td>maximum swivel wear play</td> </tr> </tbody> </table>	Symbol	Value	Description	d_{s2}	4 mm	maximum swivel wear play	<p><i>Requirement:</i> Wheel dia.: 150mm S2: max 4mm</p> <p><i>Result:</i> S2: 2.64mm</p>	P
Symbol	Value	Description							
d_{s2}	4 mm	maximum swivel wear play							
6	<p>Conformity</p> <p>On request, the manufacturer shall declare by a certificate of conformity that the castors or wheels are in accordance with the requirements as stated in this International Standard.</p> <p>The type of testing machine shall be stated in the conformity document.</p>	Test report was applied only as per client's request.	N/A						
7	Marking of the product								
7.1	<p>Product marking</p> <p>All the products shall be permanently and visibly marked with a name and/or trademark of the manufacturer.</p>	<i>Acc. to client's request not tested.</i>	N/T						
7.2	<p>Marking of electrically conductive or antistatic castors or wheels</p> <p>All products shall bear, on their outer surface, a clearly visible mark as follows:</p> <ul style="list-style-type: none"> — antistatic: a white mark and, where appropriate and possible, the word "antistatic"; — conductive: a yellow mark and, where appropriate and possible, the word "conductive". 	<i>Acc. to client's request not tested.</i>	N/T						

- END OF TEST REPORT -